

DESCRIPTION OF ICONS

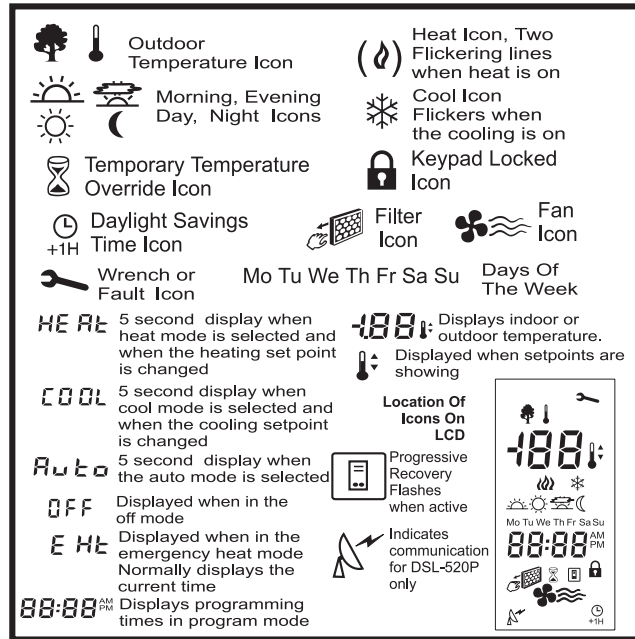

Display icons vary according to the model. Your thermostat may not display all of the icons shown.

Outdoor Hi & Lo Temperature Balance Points (Heat Pump Only)

With the optional electronic outdoor temperature sensor, you can select the outdoor balance points to inhibit the auxiliary heat and/or compressor.

HibP – Press and hold the OUTDOOR button, then press the MODE button. **HibP** will appear on the display. Raise or lower the **HibP** by pressing the ▼ or ▲ button to set the temperature above which the auxiliary heat is locked out. Press the OUTDOOR button while showing the **HibP** and the thermostat will switch to show **LobP**. **LobP** is used to lock out the compressor. Outdoor temperatures below the **LobP** will lock out the compressor. The factory **HibP** and **LobP** setpoints are +48°C and -48°C.

DIP SWITCH OPTIONS AND FUNCTIONS

Positioning the DIP switches in either the ON or OFF position enables you to choose between two different options. The DIP switches are located on the interior of your thermostat and may be accessed by following the procedure for removing the thermostat from the subbase. The following list describes your DIP switch options.

DIP Switch No.	DIP Switch OFF	DIP Switch ON
1	4 Events per day	2 events per day
2	Smart fan disable	Smart fan enable
3	4 Minute Minimum ON	2 Minute Minimum ON
4	Keypad unlock	Keypad lock
5	Normal	Add-on
6	Single stage	Multi-stage
7	LED #1 + No icon	LED #1 + Filter icon
8	LED #2 + No icon	LED #2 + Fault icon

1. 2 Events or 4 Events You may select either a 2- or 4-event schedule: 2 events include Day and Night; 4 events include Morning, Day, Evening, and Night.

2. Smart Fan With the Smart Fan switch in the ON position and the fan selected, the thermostat will keep the fan running continuously during the occupied programs and automatically cycle the fan with a call for heating or cooling during the unoccupied program. *(The unoccupied program is the Night event.)*

3. 2-Minute or 4-Minute On Times This option allows you to run the equipment for either a 2- or 4-minute minimum on and off time.

4. Keypad Lock In the ON position, locks out all buttons except the OUTDOOR button.

5. Normal or Add-On The thermostat is equipped to enhance the performance of an add-on heat pump. In most applications it will perform the function of a fossil fuel kit. Select Add-on by placing the

switch in the ON position. The thermostat will turn off the compressor with a call for auxiliary heat. With the switch set to Normal (OFF), the compressor and auxiliary heat may be on simultaneously.

6. Single or Multi-Stage Set to OFF for 1 compressor stage of heating or cooling (single stage) or ON for equipment with 2 compressor stages of heating and/or cooling (multi-stage).

7. LED and Filter Icon In the ON position the display will show the filter icon when the left LED is energized.

8. LED and Wrench Icon In the ON position the display will show the wrench icon when the right LED is energized.

SPECIFICATIONS

Rated Voltage	20-30 VAC, 24 nominal
Rated A.C. Current	0.050 Amps to 0.75 Amps continuous per output with surges to 3 Amps Max.
Rated D.C. Current	0 Amps to 0.75 Amps continuous per output with surges to 3 Amps Max.
Control Range	Heating: 38° to 88°F in 1° Steps 5° to 30°C in 1° Steps Cooling: 60° to 108°F in 1° Steps 16° to 40°C in 1° Steps
Thermostat Measurement Range	28° to 124°F or 0° to 48°C
O.D.T. Displayed Range	-50° to 119°F or -48° to 47°C
Control Accuracy	±0.5°C at 20°C, ±1°F at 68°F
Minimum Deadband	(between heating and cooling) 2°F or 1°C

Note: This thermostat contains electronic circuitry replacing the conventional mechanical anticipator.

One (1) Year Limited Warranty

The manufacturer warrants to the original purchaser that its product and component parts will be free from defects in workmanship and materials for a period of one (1) year from the date of purchase. Return to the original point of purchase for replacement of your product.

Warranty Limitations

This warranty begins at date of purchase.

Warranty is Void if:

The date code is defaced or removed.
The product has a defect or damage due to product alteration, connection to an improper electrical supply, shipping and handling, accident, fire, flood, lightning, or other conditions beyond the control of the manufacturer.
The product is not installed according to the manufacturer's instructions and specifications.

The product has been installed near sources of electromagnetic interference (EMI) such as arcing relay contacts.

Owner's Responsibility

Provide proof of purchase.
Provide normal care and maintenance.
Pay for freight, labor and travel.
Pay for service calls related to product installation.
Return any defective product.

In no event shall the manufacturer be liable for incidental or consequential damages.

This warranty gives you specific legal rights and you may have others which vary by state and/or province. For example, some states and/or provinces do not allow the exclusion or limitation of incidental or consequential damages, so this exclusion may not apply to you. The manufacturer's continuing commitment to quality products may require a change in specifications without notice.

This equipment, if installed in strict accordance with the manufacturer's instructions, complies with the limits for a Class B computing device pursuant to Subpart J of Part 15 of FCC rules.

Operating Instructions

7 Day Programmable Thermostat

Two Compressor Auto Changeover 3 Heat/2 Cool

NEW & IMPROVED FEATURES

Your new electronic programmable thermostat has been made even better by the introduction of several new and improved features. Building on its reputation for efficient and dependable operation, your thermostat now offers the following list of enhancements.

Progressive Recovery (available on programmable models) Selecting progressive recovery on your programmable thermostat causes the thermostat to anticipate the programmed setpoint change, thus allowing the climate-controlled area to reach the desired setpoint when required. The progressive recovery option is selected by pressing the FAN and PROGRAM buttons simultaneously.

Thermostat and Sensor Calibration Release 3 provides easy calibration of the thermostat and remote sensors. Simply press and hold the FAN button for 10 seconds and adjust with the up or down buttons.

Programming Revert Time Extended The programming revert time has been extended to 2 minutes.

Push Button Auto Repeat Programming is easier with the push button auto repeat feature.

Extended Backup Time The power failure backup time has been increased to 2 hours.

BUTTON FUNCTIONS

Clock	Press to set current day, hour and minute
Set Temp	Press to set the heating and cooling setpoints
Program	Press to set program days and start times. Press simultaneously with the FAN button to select progressive recovery.
Hold	Press to hold the current setting. The program will hold indefinitely or until RESUME is pressed.
Outdoor	Press to display the outdoor temperature (optional)
Mode	Press to select cool only, heat only, auto (cool & heat), or off
Fan	Press for continuous fan or auto fan
Resume	Press to exit the hold or override program or when programming is complete.
▼ ▲	Press down or up buttons during programming and overrides to lower or raise setpoints and change the day and time

Selecting Fahrenheit or Celsius Display Simultaneously press the ▲ and ▼ buttons to switch between Fahrenheit and Celsius.

Changing the Clock from 12 to 24 Hour To change the time indicated from 12 hour to 24 hour, press and release the CLOCK button, then press the MODE button.

Power Outages/Failures During Regular Program Schedule Should your power fail at any time during the regular program, the thermostat will maintain the clock internally for up to 2 hours. If the power has not been restored during this time period, the clock will stop. When the power is restored, the thermostat clock defaults to a flashing 12:00 AM. **The thermostat will be held in the Night program until the user resets the clock.** The thermostat will display AC when the 24 VAC is not powered. One of the unique features of your thermostat is that there is no battery required to maintain your selected setpoints in the event of a power loss, since the memory is unaffected by power failures of any duration. There is no reason to reprogram the setpoint temperatures or start times since the thermostat will retain these program parameters.

UNDERSTANDING 7 DAY PROGRAMMING

It is recommended that you read and understand these instructions before you attempt to program your new thermostat.

Programming your thermostat involves selecting the temperature you want in your home and selecting the time you want it to be that temperature.

Each time schedule is known as an event. An event ends at the same time that the next event begins so only a starting time for each event is required.

Your thermostat allows you to choose between a 2-event (Day and Night) or 4-event schedule. This is a DIP switch selectable option. For a more detailed description of event options refer to "DIP Switch Options and Functions."

Event = Morning ☀, Day ☀, Evening ☁, Night ☾
Event Time = the time the event starts
Event Setpoint = the temperature set during the event; each event can have only one heat and one cool setpoint

The Morning event is typically when you wake up and is the first event of the day. The Day event is normally set when you leave for work. The Evening event is usually set for when you arrive home. The Night event is set when you go to bed.

Each event will have two (2) temperatures: 1 heating temperature and 1 cooling temperature. The cooling temperature must be at least 2 degrees Fahrenheit higher than the heating temperature. The event setpoints are programmed once for all seven (7) days. The thermostat allows a different program for each day of the week. Complete the chart labeled "Set Your Personal Schedule" with your desired temperatures and time schedules before beginning programming.

To exit programming at any time, press and release the RESUME button, or 2 minutes after pressing the last button the display will automatically change to the normal display.

PROGRAMMING THE THERMOSTAT

Setting the Current Day and Time

1. Press and release the CLOCK button. The display will flash MO for Monday.
2. Press the ▼ or ▲ button until the current day appears on the display.
3. Press the CLOCK button to select the hour. The display will flash 12:
4. Press the ▼ or ▲ button until the current hour appears on the display. Be sure the AM or PM corresponds to the proper time.
5. Press the CLOCK button once again to select the minutes. The display will flash :00.
6. Press the ▼ or ▲ button until the current minutes appear on the display.
7. Press RESUME or wait for the regular display to appear.

You have now set the current day and time on the thermostat and are ready to begin programming the details of the events and setpoints.

Program the Events

The event programming procedure that follows assumes the thermostat is in the AUTO mode and set for 4 events per day (DIP switch #1 set in the OFF position). If you require only 2 events per day you may change this option by setting DIP switch #1 to the ON position. Refer to "DIP Switch Options and Functions" for details. The programming procedure remains the same except that

you will not have the option of programming for the Morning or Evening events.

1. Press and release the SET TEMP button.
2. You will see a Morning ☀ or Day ☀ icon;
 - * a heating ⬆ or cooling * icon;
 - * a flashing setpoint 10 (temperature).
3. Select the desired setpoint by pressing the ▼ or ▲ button.
4. Press and release the SET TEMP button to move to the next event. Continue until all Morning, Day, Evening and Night events and heating and/or cooling setpoints are programmed.

Setting the Event Start Times

1. Press and release the PROGRAM button.
2. You will see a Morning ☀ heating ⬆ or cooling * icon, setpoint 10, flashing MO (Monday) or current day of the week.
3. Select the desired weekday by pressing the ▼ or ▲ button.
4. Press and release the PROGRAM button.
5. Select the desired hour by pressing the ▼ or ▲ button.
6. Press and release the PROGRAM button.
7. Select the desired minute (if necessary) by pressing the ▼ or ▲ button (in increments of 10 minutes).
8. Press and release the PROGRAM button to move to the next event.
9. Repeat the process until all of the desired event start times have been programmed.

Copy the Events to Other Days

Once you have gone through the programming procedure for Monday, ending at the Night ☾ event, the word COPY will appear. You may choose to copy the 4 event start times to other days of the week. Press the ▼ button to display all the days of the week. Press the ▲ button to select the consecutive days of the week that you want the events to apply to. Press the PROGRAM button to do the copy or press the RESUME button to return to the normal display.

Individual Days

If certain days of the week require different event starting times, follow the procedure below.

1. Press and release the PROGRAM button.
2. Press the ▼ or ▲ button to advance the day indicator to the desired day.
3. Press and release the PROGRAM button to change the event hours and minutes to the desired starting times as in "Setting the Event Start Times."
4. Press the RESUME button to return to the normal display.

Skipping an Event (2 Methods)

Your personal schedule may not require the use of all 4 events on a weekday. For example, if you wish to go from the Day event directly to the Night event and skip over the Evening event, there are 2 methods you can use:

- A) - Press and release the PROGRAM button until you come to the day and event hour on the day that you wish to skip.
 - Press and hold down the PROGRAM button and at the same time press and release the MODE button. In the time display area you will see " _ : _ : _ " indicating that the event is skipped.
- B) If any two or more events have the same start time, the latest event in the day has priority and therefore uses its setpoints.

Reviewing Scheduled Times

To review the program schedule, repeatedly press and release the PROGRAM button. Each of the scheduled events is displayed

starting with the temperature, day, hour and minute for each day of the week. To cancel your review, press the RESUME button, or simply wait 2 minutes for the thermostat to resume the display automatically.

Reviewing Programmed Temperatures

To review your programmed temperatures, repeatedly press the SET TEMP button. The display will change to show the mode, event, and the setpoint selected.

Viewing the Outdoor Temperature (Option)

If your thermostat has been installed with an electronic outdoor remote sensor, you may view the outdoor temperature simply by pressing the OUTDOOR button. Upon releasing the button, the thermostat will once again display the indoor temperature.

Temporary Temperature Override

To temporarily change the scheduled setpoint during an event without affecting the program, press the ▼ or ▲ buttons to lower or raise the setpoints. The new setpoint will be retained for 3 hours and will not affect the programming schedule. You may return to the regular program schedule by pressing the RESUME button.

Temporary Temperature Override with Keypad Locked

(The keypad may be locked to prevent tampering by selecting the ON position of DIP switch #4.)

With the keypad locked to prevent tampering you may temporarily adjust the setpoint by ±3°C or 6°F of the programmed morning (4 event) or day (2 event) setpoint without affecting the regular program. Press the ▼ or ▲ button to raise or lower the setpoint for a 1 hour period. This override may not be cancelled by pressing the RESUME button.

Constant Override

To maintain a temperature setting for an indefinite period of time, press the HOLD button. The word HOLD will appear on the LCD. The current scheduled setpoint will be maintained. To select a different setpoint, press the ▼ or ▲ button to raise or lower it. The last setpoint selected (scheduled or new) will be maintained continuously until the RESUME button is pressed.

Off Mode

To turn off the heating or cooling system, press the MODE button until the word OFF appears on the LCD. It will remain displayed until the mode is changed. The OFF mode prevents the system from being energized. **Avoid** using the OFF mode during extremely cold weather to prevent damage to the equipment from freezing.

Auto Changeover Mode

To set the thermostat to automatically switch from heating to cooling, press the MODE button until the word AUTO and both the heating ⬆ and cooling * icons appear on the LCD. The thermostat energizes the heating or cooling system based on the temperatures established for both modes.

SET YOUR PERSONAL SCHEDULE

5/2 Day programmable									
Event	Temperature Settings			Event Start Times					
	Weekday Set points	Mon	Tues	Wed	Thurs	Fri	Sat	Sun	Week end Set points
Morning ☀	Cool Heat								Cool Heat
Day ☀	Cool Heat								Cool Heat
Evening ☁	Cool Heat								Cool Heat
Night ☾	Cool Heat								Cool Heat
Use this blank chart to determine your personal schedule. Write in the appropriate location your desired heat/cool temperature set points and the times to start for each day.		☀ To not use a particular event, select the event, hold the PROGRAM button in at the hour or minute section, then press the MODE button. Four dashes will appear in the hour and minute section. -- : --							

This blank list is for your own use. Start by selecting your heat/cool temperature setpoints. Determine the times you want the temperatures to be active. Write in the desired times in the appropriate location. Typically programming would begin on Monday, allowing you to copy the Monday schedule to the consecutive days of the week.

INSTALLATION INSTRUCTIONS

CAUTION
THIS DEVICE SHOULD BE INSTALLED BY A QUALIFIED TECHNICIAN WITH DUE REGARD FOR SAFETY, AS IMPROPER INSTALLATION COULD RESULT IN A HAZARDOUS CONDITION

Location

Mount the thermostat on an inside wall in a frequently occupied area of the building. Its position must be at least 18" (46cm) from any outside wall, and approximately 5' (1.5m) above the floor in a location with freely circulating air of average temperature. Avoid the following locations:

- behind doors or in corners where circulating air is unavailable
- where radiant heat from appliances might affect control operation
- on an outside wall or door, in direct sunlight or in stairwells
- adjacent to, or in line with, conditioned air discharge grilles
- where operation may be affected by steam or water pipes or warm air stacks in an adjacent partition space, or by an unheated/uncooled area behind the thermostat
- where its operation is affected by supply air of an adjacent unit
- near electrical interference (e.g., arcing relay contacts).

Removing the Thermostat from the Subbase

1. Insert a flat blade screwdriver or a coin 1/8" into the slot located in the bottom center of the thermostat case and twist 1/4 turn. When you feel or hear a "click," grasp the case from the bottom two corners and separate from the subbase. Some models require more force than others when separating.
2. Swing the thermostat out from the bottom.
3. Lift the thermostat up and off the subbase.
4. Place the rectangular opening in the subbase over the equipment control wires protruding from the wall and, using the subbase as a template, mark the location of the two mounting holes. (Exact vertical mounting is necessary only for appearance.)
5. Use supplied anchors and screws for mounting on drywall or

Thermistor Mounting Instructions (cont'd)

Ensure the thermistor is not pushed upward into the case. The thermistor should be aligned so it is visible between the ribs on the bottom of the subbase.

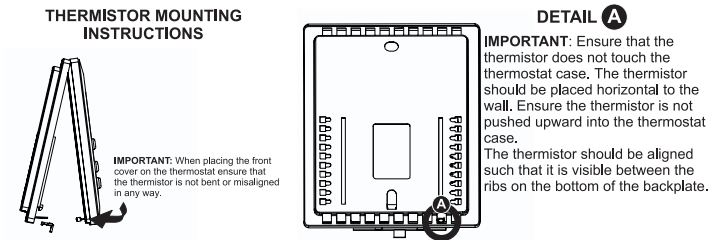

WIRING DIAGRAM

This thermostat may be used with 24V DC. The negative side of the DC supply must be wired to the 24V(c) terminal.

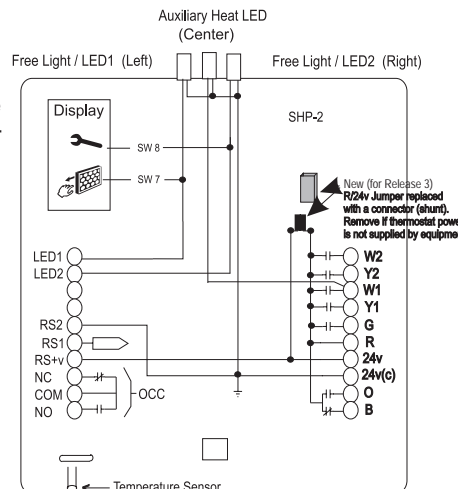

- plaster; drill two 3/16" (5mm) diameter holes at marked locations; use a hammer to tap nylon anchors in flush to the wall surface and fasten subbase using supplied screws. (Do not overtighten!)
- 6. Connect the system wires to the thermostat terminals as shown in the wiring diagrams. Carefully dress the wires so that any excess is pushed back into the wall cavity or junction box. Ensure that wires are flush to the plastic subbase. The access hole should be sealed or stuffed to prevent wall drafts affecting the thermostat.
- 7. Before the thermostat is reinstalled on the subbase, install the optional clock/timer, indoor remote sensor and outdoor remote sensor, if used. Refer to installation instructions supplied with each. Also check DIP switch positions on the back of thermostat.

Replacing the Thermostat on Subbase

1. Position the thermostat on the hinged tabs at the top of the subbase.
2. Gently swing the thermostat down and press on the bottom center until it snaps into place.

Thermostat Cover Lock

Insert the plastic lock piece into the bottom of the mounted base. The ends of the lock piece fit snugly under the lock pins extending from the bottom of the mounted base. The tab in the middle of the lock piece extends down from the base. To release the locking mechanism, press the lock piece up and into the base while gently prying open.

Thermistor Mounting Instructions

When placing the front cover on the thermostat, ensure the thermistor is not bent or misaligned. Ensure that the thermistor does not touch the thermostat case. The thermistor should be placed horizontal to the wall.

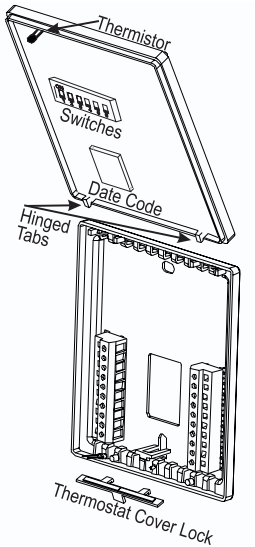

TERMINAL DESIGNATIONS

- W2** . . . Energizes second stage auxiliary heat in emergency heat mode
- Y2** . . . Energizes compressor #2 on a call for second stage heating or cooling
- W1** . . . Energizes auxiliary heat as last stage heating or first stage emergency heat
- Y1** . . . Energizes compressor #1 on a call for first stage heating or cooling
- G** . . . Fan is energized with a call for heating or cooling or by pressing the FAN button
- R** . . . Power from equipment
- 24V** . . . 24 VAC hot and common to power the thermostat
- 24V(c)** . . . Energizes reversing valve continuously in cooling mode
- B** . . . Energizes the reversing valve continuously in the heating & off modes
- RS2** . . Use to connect up to 6 (SL-IDS) indoor and/or 1 (SL-ODT) outdoor remote sensor/s.
- RS+V** . . When connected the thermostat will automatically use the SL-IDS temperature sensor and not its own. Refer to the instructions included with the sensor
- NO** . . . NO and common connected during Night mode, default
- COM** . . with AC failure, OCC (occupied/unoccupied) relay de-energized
- NC** . . . NC and common connected during Morning, Day and Evening programs, OCC (occupied/unoccupied) relay energized
- LED1** . . Free status light when energized lights LED1. Also see Sw7
- LED2** . . Free status light when energized lights LED2. Also see Sw8 (Installer should identify what the LEDs are being used for.)